

Technical Data Sheet

LEMNOS 600mm Isocast Basin

Whats in the box: 1x INST047073

INSTINCT®

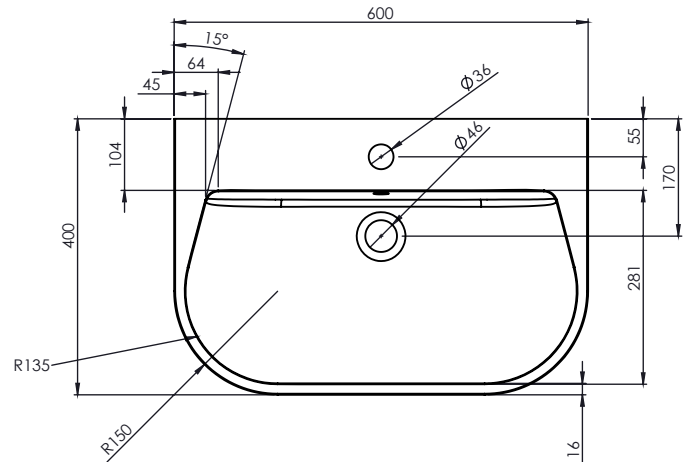
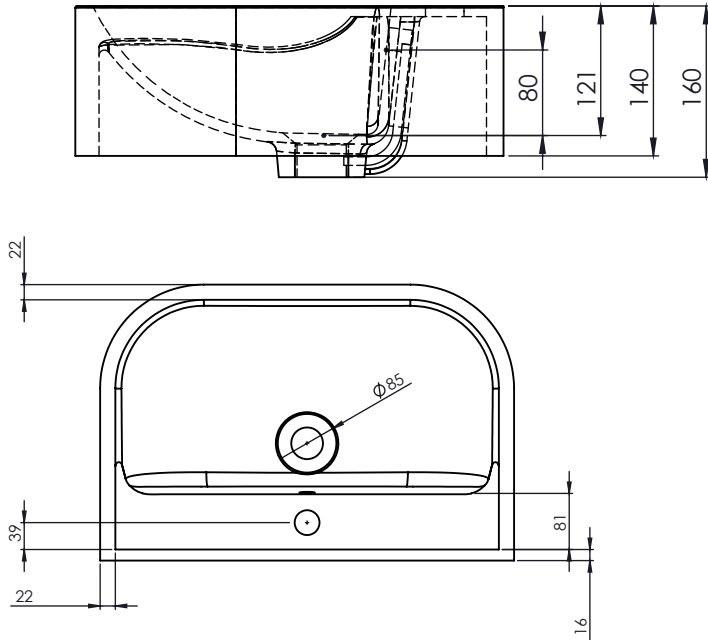

Diagrams not to scale
All dimensions in mm
tolerance of +/-5mm

*Dimensions are subject to change, customers are advised to measure actual product before commencing installation.

**Fixing point dimensions are for guidance only/the positions of wall fixing must be checked when product is received.

Materials

Basin: Isocast

Has many names including:

- Gelcoat
- Cultured marble
- Cast mineral marble
- Synthetic marble

All Roper Rhodes basins are produced in Swedish owned Polish factory who were one of the first to market with this material the 1970s. Base material is 70% natural (aggregate dolomite rock - calcareous magnesium carbonate). A misconception is that this material is completely manmade. The other 30% is a mixture of various polyester resins. 1.5 - 2.0mm Top coating of "gelcoat" which is the proprietary name for the polyester resin used to seal all top faces of the basin / worktop. This can be glossy or matt. Tolerance of +3/-0mm. Ceramic is more typically +5/-5mm. Fully tested against multiple stains which can either be removed with standard cleaners (autosol for example) or the specialist clean and shine repair kits.

Product is tested and approved by the following associations:

- CE, IAPMO R&T (USA), Building research institute.

FAQs

Q: What is the maximum water depth of the basin?

A: 80mm up to the overflow.

Q: What is the distance of the wall fixings?

A: N/A

Q: Whats is the depth of the Tapledge?

A: The Tapledge is 104mm deep.

Q: What is the distance from the Taphole centre to Basin Waste?

A: 115mm