

INSTALLATION INSTRUCTIONS - WFSTAT OPTIMUM VIBE PROGRAMMABLE THERMOSTAT



Transmitter



Receiver



The OPTIMUM VIBE - Model OP-WFSTAT is a radio frequency programmable thermostat, with dual radio frequency / WiFi receiver. It **MUST** be installed by a qualified person, in accordance with best practise and current IEE wiring regulations. Before programming, complete all set-up instructions.

The transmitter is battery-powered (2 x AAA alkaline); the receiver is mains-powered, with volt-free switching. The control set uses the license - free 868 MHz radio frequency to communicate between transmitter and receiver, and the ISM 2.4 GHz frequency to communicate with your WiFi router, compliant with WLAN 802.11 b/g/n

Installation procedure: transmitter and receiver positioning

The receiver should normally be wall-mounted close to the boiler, and should share a mains supply from the same circuit that powers the heater / boiler. However avoid locating it directly next to the boiler's case - see ¹ below.

The transmitter should be located within the property bearing in mind the following requirements:

The transmitter has an in-built temperature sensor, which it uses to detect ambient temperature, and calculates whether to send a demand or no-demand signal to the receiver. The transmitter should be located in a main living area, where it is visible, has a free air-flow and is not unduly influenced by draughts or extraneous heat sources: e.g. radiator / direct sunlight / lamp— please refer to the diagrams below:

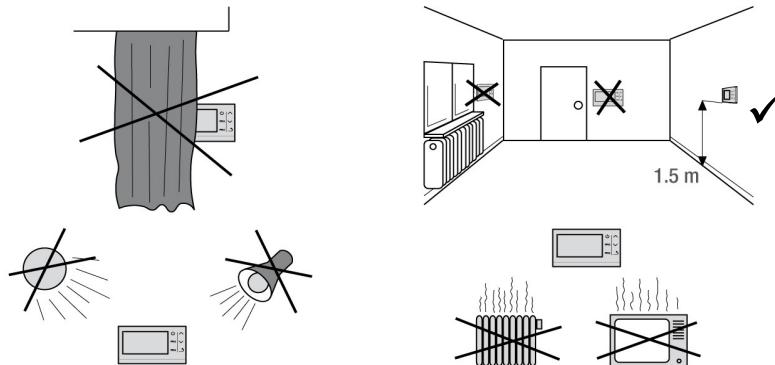

¹ The radio-frequency signal range is 20 to 30 metres in conventional brick / timber / tile structures. Note that metallic materials such as reinforced concrete and foil-backed plasterboard will reduce or in some cases block the radio frequency signals. It is best to position both transmitter and receiver so that they are not close to large metallic objects, and bear in mind that mirrors reflect radio waves in the same way they reflect light.

Transmitter - installation

Place 2 x AAA alkaline batteries in the battery compartment at the back of the transmitter; ensure correct polarity.

Set the time and day: After inserting batteries, the transmitter will jump to time-setting mode, or during normal operation, touch SET for five seconds, change the minutes, touch SET, change the hours, touch SET, change the day, touch SET. Then touch the ON/OFF icon to put in run mode. Full set-up can be completed later.

The transmitter can be wall-mounted, or placed on a table-top or counter, using the back-plate or the stand included in the carton. If wall-mounting, fix the back-plate to the wall observing the UP ↑ ↑ marks, align the top two recesses on the back of the transmitter, to the top two lugs on the back-plate, then rotate downwards to 'click' the other two lugs in place. Reverse this procedure to remove the transmitter from the back-plate. **Note that** - if you hold the transmitter for longer than a few seconds, it will start to detect your body temperature, rather than the ambient room temperature, and this will affect the calculation of demand / no demand for heat. Replace the transmitter onto the back-plate or stand so that it will again start to detect the ambient room temperature.

Receiver - installation

The receiver should be wall-mounted in a clean, dry environment. It is a class II control, suitable for ambient temperature from 0 to 50°C. It has 60mm wall-fixing centres which are compatible with standard back-boxes. A back-plate channel is provided if wiring has to be surface-run. The receiver requires a 230 volt live and neutral supply, and controls a volt-free changeover switch, as well as an Open Therm® polarity-free output. Separate the receiver top cover from the base by gently levering the cover upwards with a flat-bladed screwdriver placed into the two slots on the underside. Fit the receiver to the wall, and connect to the terminals provided. See the wiring diagrams below:



*Before connecting the receiver to the boiler, **make sure** that you have followed the boiler external thermostat connection instructions. **A mains connection to a volt-free terminal could damage the boiler circuitry.***

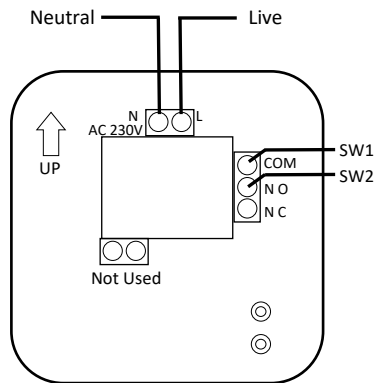

Wiring for volt-free switching:

Connect 230V AC Live and Neutral to L & N
 Connect the volt-free boiler connections (SW1 / SW2) to COM & N O (common and normally

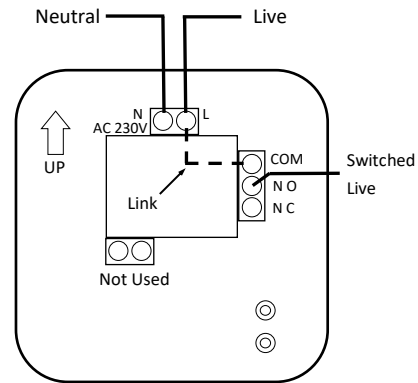

Wiring for mains switching:

Connect 230V AC Live and Neutral to L & N
 Fit a short link wire between L & COM
 Connect the (230V mains) switched live to N O

The VIBE receiver is a double-insulated Class II control without earth connection. Use a separate single screw terminal block if earth continuity is required. After wiring clip the cover on top of the installed receiver: apply light pressure until the housing clicks into place.

Power-up the control set and complete the setting up procedure.

After fitting batteries to the transmitter; fitting the receiver to the wall and installing wired connections appropriate for the heating appliance, switch on the mains supply to the receiver. The green Power LED should be visible on the receiver. The green LED will flash 1 x per second. Now check the receiver response: keep the transmitter approximately 1 to 2 metres from the receiver, and touch the UP arrow to raise the SET temperature above the measured ROOM temperature. Within 2 or 3 seconds the **demand symbol** (see left) should appear in the display, and within a further ~10 seconds, the receiver Heating on LED should illuminate. There is an audible click as the switching relay operates. The heating appliance should now be running. The receiver can also be operated manually by briefly pressing the centre **override button**. Note that if the transmitter is left in demand mode after the receiver is manually overridden to off (and vice-versa), the transmitter will re-assert control and switch back on approximately 10 minutes later.



The transmitter and receiver control set is pre-commissioned at the factory. Refreshing of the RF link is possible (see **Refresh RF Link** on page 4), but this should not be necessary. The transmitter and receiver should communicate as soon as they are both powered-up. If there is a problem, make sure that:

- the green Power LED on the receiver is illuminated. If not, check the mains supply and ensure the receiver is on. If necessary, briefly press the receiver ON/OFF button.
- the demand symbol is visible in the transmitter's LCD. If not, increase the SET temperature to at least one degree above the ROOM temperature. The demand symbol should be visible within three seconds.

Assuming the receiver response is O.K., proceed to the rest of the setting-up procedure.

Transmitter and receiver display / controls

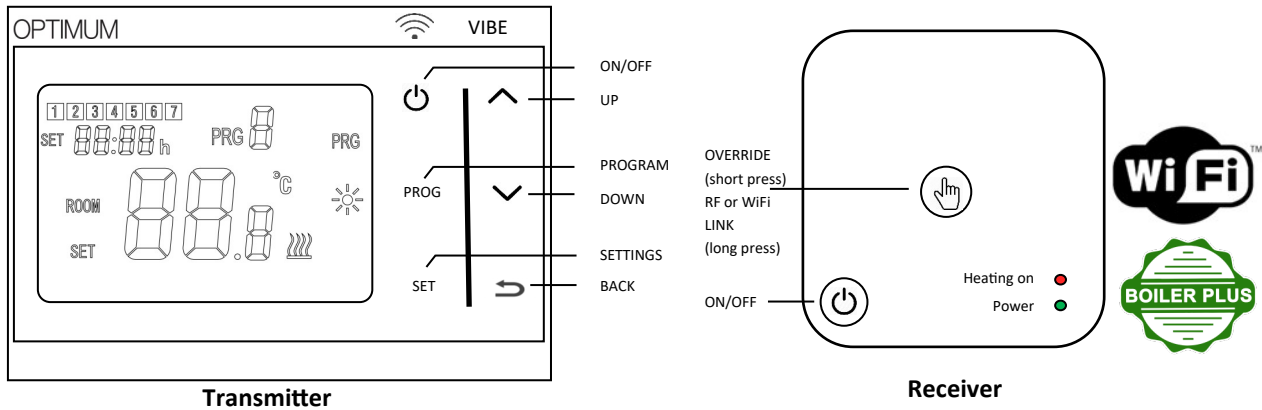

Parameter setting — how to configure the way your Optimum Vibe thermostat works: SET + ^

To open the configuration menu, first touch the transmitter ON/OFF button to turn the display off (touch any button to ‘wake-up’ the transmitter, then touch the ON/OFF button to turn off), then touch the SET and UP buttons at the same time for 5 seconds:

You can review 21 options which can be configured to adjust the operation of the OPTIMUM VIBE.

Touch the UP or DOWN arrows to adjust the parameter, and touch SET to move sequentially through the options. Changes will be saved by pressing the ON/OFF button. If no button is touched for 10 seconds, the display will ‘time-out’, but your changes will still be saved.

Option	Description	Range	Default value
01	Temperature calibration	-8°C ~ +8°C	0°C
02	Maximum temperature setting	5°C ~ 35°C	35°C
03	Minimum temperature setting	5°C ~ 35°C	5°C
> 05	Frost-protection temperature	OFF (- - in config. Screen), or 5°C ~ 15°C	5°C
09	Hysteresis (differential)	0.5°C ~ 3.5°C	0.5°C
> 11	Child lock	0: Unlock 1: Lock	0
17	Reset (reset all values to default)	Change to 1; touch Power button for 5 secs	0
18	Firmware code	Non adjustable *	5091
19	Firmware code	Non adjustable *	0113
50	Backlight	0: OFF 1: AUTO	1
> 52	Temperature regulation mode	NOr: Normal (ON/OFF) OPs: Optimum Start tPi: Time Proportional / Integral	NOr
> 53	Time interval for Ops	10 min, 15 min, 20 min	20 min
> 54	Number of heating cycles/hour	Range: 2 ~ 3 ~ 6 ~ 12	6
> 55	Proportional Bandwidth	Range: 1.5°C— 3°C	2°C

> See additional notes about these configuration options on Page 4

* Firmware is pre-loaded in the factory, and visible for reference but cannot be changed.

59	Spare program space		
60			
61	Spare program space		
62	Spare program space		
63	Spare program space		

Configuration options—additional notes:

Option	Description
05	If you set a frost-protection temperature, the heating will be switched on when the measured temperature falls below this level, even if the transmitter has been turned off.
11	When receiver connected via ON/OFF terminals, this setting can be adjusted via the transmitter or the App.
52	Please read 'how it works' for a full explanation of temperature regulation modes
53	Set if you chose OPs (Optimum Start) regulation. For the best results, the time interval selected should approximate the time taken to increase the room temperature by 1 degree.
54	Set if you chose TPI regulation. Select a lower number for heating systems with a slow response, and a higher number for heating systems with a fast response.
55	Set if you chose TPI regulation. Sets the temperature below the set-point at which TPI control will begin



Initiate WiFi link / Refresh RF link

Press and hold the centre **override button** on the receiver until the Heating on LED flashes rapidly. Release the override button—the LED must still be flashing. For **WiFi LINK**—see WiFi instructions.

RF LINK: Turn off the transmitter by touching the ON/OFF icon. The display will go blank. Now touch the SET icon for 5 seconds. A unique pre-set four-character code will show in the top left of the display. Release and then briefly touch the SET icon once more. The receiver LED will stop flashing and the RF link has been refreshed. Quit back to normal running mode by touching the ON/OFF icon.

Turn on the transmitter by touching the ON/OFF icon, to bring the VIBE back into service.



Receiver ON / OFF

You can turn off the receiver. The receiver's output will switch off, and it will stop responding to the transmitter.

Transmitter ON/OFF

You can save battery power on the transmitter, by touching the ON/OFF icon. The transmitter is switched off and will stop sending control signals; **the receiver will also switch OFF until you turn the transmitter back on.**

Specification:

868 MHz radio frequency control between transmitter and receiver, with 4 character hexadecimal coding giving 65,536 code combinations. Transmitter power 2 x AAA alkaline. Touch-screen keys. 70 x 40mm backlit LCD. Dimensions 120 x 85 x 22.5mm. Dual RF and WiFi 2.4 GHz receiver: power 230V AC, volt-free changeover 10A (resistive) switching, ON/OFF & manual override buttons. Dimensions 85 x 85 x 25mm. Wall-fixing centres 60mm.

Set control features: 20—30m range in buildings. ON/OFF, Optimising & TPI temperature regulation. Hysteresis +/- 0.5°C. 5 & 2 or 7 day programming. 4 time / temperature periods. Temperature range 5—35 °C.

Boiler Plus compatible: Class IV control, 2% contribution to system efficiency

Approvals: CE - Radio Equipment Directive EN 2014/53/EU - RoHS

Do not dispose of this product with household waste - use local recycling facilities

