

Data sheet revision: A

**SEN02CP**

SENATE BATH TAPS

**Product description**



**Working parameters**

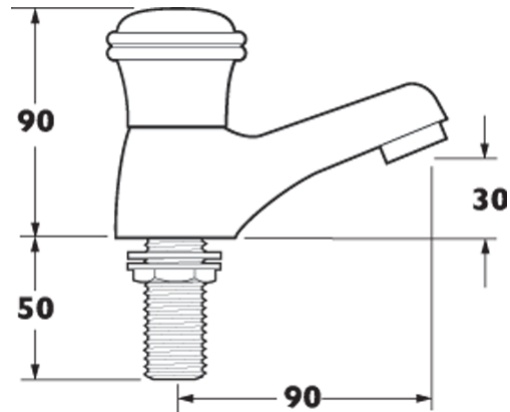

Pressure (BAR)	0.1	0.2	0.3	0.5	1.0	1.5	2.0	2.5	3.0	3.5	4.0	4.5	5.0
Single outlet (L/MIN)	10.8	13.9	16.2										

Pressure (BAR)	0.1	0.2	0.3	0.5	1.0	1.5	2.0	2.5	3.0	3.5	4.0	4.5	5.0
2nd outlet WITHOUT handset (L/MIN)													

Pressure (BAR)	0.1	0.2	0.3	0.5	1.0	1.5	2.0	2.5	3.0	3.5	4.0	4.5	5.0
2nd outlet WITH handset (L/MIN)													

# Parts breakdown diagram

REVISION HISTORY				
REV	DESCRIPTION	DATE	AUTHOR	APPROVED
A	Drawing released	04/10/2005	Ian Parker	Chris Smith

ITEM	QTY	PART NUMBER	DESCRIPTION
6	1	99-058	SEN02 Body
1	1	01-027/01-028	Senate Indice
3	1	58-003	Senate Handle Ring
4	1	03-052	Senate Handle
5	1	05-003	1/2" BSP Rising Spindle Valve (21 x 20)
7	1	42-004	3/4" Backnut Washer
9	1	23-017	15mm Snap Washer ( for 20mm Antisplash)
10	1	10-012	20mm White Antisplash
11	1	10-013	Holder For 20mm White Antisplash
2	1	02-005	M4x0.7 10mm Long Screw
8	1	55-003	3/4" BSP Backnut

<b>MATERIAL:</b> TOLERANCE: (UNLESS OTHERWISE STATED) ALL RADIUS 0.5mm, ALL CHAMFER 0.5mm LINEAR TOLERANCE 0 - 50mm ± 0.2mm, 50 - 250mm ± 0.5mm, 250mm - 500mm ± 1.0mm, 500mm+ ± 2mm ANGULAR TOLERANCE ± 1.0°, RADIUS TOLERANCE ± 0.5mm, DIAMETER TOLERANCE ± 0.5mm CONCENTRIC TOLERANCE ± 0.2mm, CASTING WALL THICKNESS TO BE NO LESS THAN 2mm	<b>SCALE:</b> 1:1	<b>PLATING AND FINISH:</b> CHROME - 0.2microns MIN DEPOSIT, NO SURFACE DEFECTS NICKEL - 10.0microns MIN DEPOSIT, NO SURFACE DEFECTS GOLD - 0.02microns MIN DEPOSIT, NO SURFACE DEFECTS ALL SURFACES TO BE POLISHED TO MIRROR FINISH  This drawing is the property of DEVA TAP CO LTD and must not be altered, copied or passed on without prior permission from the QUALITY / TECHNICAL department at DEVA TAP CO LTD	<b>DRAWN BY:</b> ianp <b>DATE:</b> 04/10/2005 <b>DESCRIPTION:</b> Parts breakdown diagram <b>PART NUMBER:</b> SEN02-000 <b>ISSUE:</b> A <b>SHEET:</b> 1 / 1
---	----------------------	---	--

SEN02CP technical data sheet generated Wednesday 6/4/2011 4:21 PM on the Deva technical database from user Sarina.kundi